



PCF40/50

Proudly designed in the UK, Precision's high performance, easy to use Blast Chiller / Freezer/ Thawing cabinets have been designed to provide energy efficient and reliable Chilling, Freezing & Thawing solutions in commercial kitchens all around the world.

Available in under counter and reach-in models with capacities ranging from 15kg to 50kg per 90 minutes chilling or 240 minute freezing cycle. All models accommodate gastronorm GN1/1 pans.

Key Features:

Stainless Steel Interior & Exterior

Intuitive Digital Control Panel

Blast Chill +90 To +3°C In 90 Minutes*

Chill Store 0 / +3°C

Blast Freeze +90 To -18°C in 240 Minutes*

Freeze Store -18 / -20°C

Choice Of Time Or Food Probe Control

Automatic Storage At End Of Each Blast Cycle

Automatic Defrost At End Of Each Blast Cycle

Thawing Mode For Controlled Defrosting Of Frozen Food

R404A Refrigerant

Zero ODP Injected Polyurethane Insulation - 60mm

Ergonomic Flush Door Handle

Gastronorm Shelving System - Anti Tilt Slides

Condensing Unit Safety System To Protect Compressor From Blocked Condensers

Self Closing Door

Heavy Duty Brake & Swivel Castors

Automatic Condensate Vaporiser System

*All Quoted Times/Weights Depend On Product, Water Content & Density



PCF15

Options:

Nylon Coated Shelves - GN1/1

Stainless Steel Shelves - GN1/1

GN1/1 Pan Set - 40mm Deep

Stainless Steel Back

Adjustable Legs

Left Hand Hinged Door

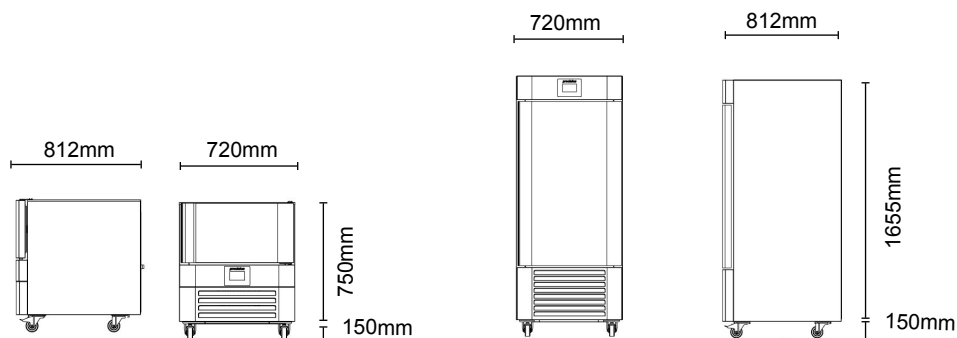

PCF15

PCF40/50

Model	PCF15	PCF40	PCF50
Type	Blast Chiller / Freezer	Blast Chiller / Freezer	Blast Chiller / Freezer
Material	ST/ST Int/Ext	ST/ST Int/Ext	ST/ST Int/Ext
Shelf Size	GN1/1	GN1/1	GN1/1
Pairs of Tray Slides Supplied	3	10	15
Max Number of Trays/Shelves (not supplied)	3	10	15
Temperature Range	+90 / +3°C +90 / -18°C	+90 / +3°C +90 / -18°C	+90 / +3°C +90 / -18°C
Exterior WxDxH (mm)	720x812x900	720x812x1805	720x812x1805
Chilling / Freezing Capacity (kg)	15	40	50
Weight (KG)	85	180	185
Refrigerant	R404A	R404A	R404A
Refrigeration Watts (+45°C Condensing)	1510 / 500	1928 / 562	2814 / 623
Evaporating Temp	-5°C / -30°C	-5°C / -30°C	-5°C / -30°C
Heat Rejection Watts*	2807	3636	4725
Power	220 / 50 / 1	220 / 50 / 1	220 / 50 / 1
Running Amps	3.9 / 3	7 / 4.5	8.9 / 5.8
Total Electrical Load - kW	0.86/ 0.66	1.54 / 0.99	1.96 / 1.28

* Heat Rejection is taken at the listed evaporating and condensing condition. Watts is calculated by taking the total power of the cabinet.

We are constantly innovating and improving our products. Please always check our website for the most up-to-date version of this spec sheet