

PPC410
with optional drawers

Proudly designed in the UK, Precision's Prep Counters provide the best in refrigerated preparation counters for commercial kitchens all around the world.

Whether it be for salads, pizzas, sandwiches, tapas, desserts and much more, these prep counters are perfect for those who need to maintain their ingredients at safe temperatures all day long.



GN Pan Layout

Key Features:

Stainless Steel Interior & Exterior

Rear Mounted 32°C Ambient Rated Refrigeration System Requires Rear & Top Ventilation

Full Width Rear Mounted Evaporator

Gentle Air Flow Over Top Of Pans

Anti-Drip Worktop

R134A Refrigerant

Zero ODP Injected Polyurethane Insulation - 60mm

+1 / 4°C Refrigerator Temperature Range

Electronic Controller With Easy Read LCD Screen

Hot Gas Defrost

Retractable Night Blind When Pans Not In Service

Rifle Bore Coated Evaporators

Integrated Flush Door Handle

Gastronorm GN1/3 Sized Pan Grid

Hi / Lo Audio Visual Temperature Alarms

Condensing Unit Safety System To Protect Compressor From Blocked Condensers

Adjustable Legs

Waste Heat Recovery Condensate Vaporiser System

Options:

Door/Drawer Locks

Bank of 2 Drawers - H - (195/195mm Depth)

Bank of 3 Drawers - T - (100/150/150mm Depth)

ST/ST Back

GN Pan Sets

Precision Connect

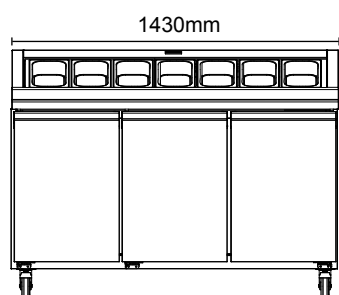

PPC307

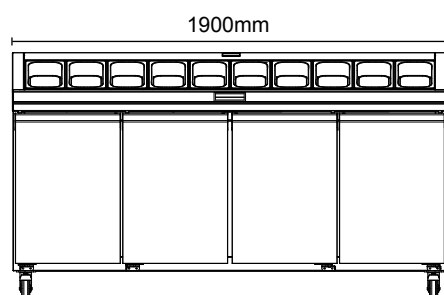

PPC410

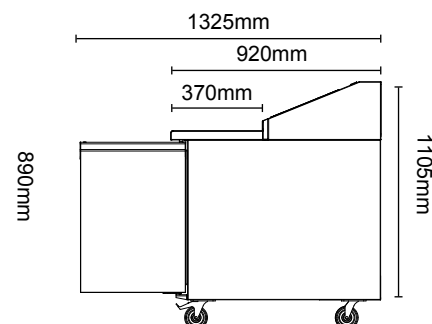

Model	PPC307	PPC410
Type	Refrigerator	Refrigerator
Material	ST/ST Int/Ext	ST/ST Int/Ext
Shelf Size	GN1/1	GN1/1
Number of GN1/3 Pans Accepted (150mm Deep)	7	10
Number of Shelves	6	8
Temperature Range	+1 / 4°C	+1 / 4°C
Exterior WxDxH (mm)	1430x920x1105	1900x920x1105
Weight (KG)	150	240
Refrigerant	R134a	R134a
Refrigeration Watts (+45°C Condensing)	790	790
Evaporating Temp	-10°C	-10°C
Heat Rejection Watts*	1312	1325
Power	220 / 50 / 1	220 / 50 / 1
Running Amps	4	4.1
Total Electrical Load - kW	0.88	0.90

* Heat Rejection is taken at the listed evaporating and condensing condition. Watts is calculated by taking the total power of the cabinet.

We are constantly innovating and improving our products. Please always check our website for the most up-to-date version of this spec sheet